

# AVERY DENNISON MARKETING SPECIFICATION

## HISTORY

REV.	DATE	DESCRIPTION
C	10/16/09	UPDATE DRAWING FORMAT
D	07.30.15	CHG. mm TO BE PRIMARY DIMS UPDATED DIM 4 AND 5

THE SUBJECT MATTER DISCLOSED HEREIN EMBODIES PROPRIETARY INFORMATION WHICH IS THE CONFIDENTIAL PROPERTY OF THE AVERY DENNISON CO. NONE OF WHICH SHALL BE COPIED, REPRODUCED, DISCLOSED TO OTHERS, PUBLISHED OR USED IN WHOLE OR IN PART, FOR ANY PURPOSE OTHER THAN THAT FOR WHICH IT IS BEING MADE AVAILABLE WITHOUT THE EXPRESS ADVANCE WRITTEN PERMISSION OF A DULY AUTHORIZED AGENT OF THE COMPANY. THIS DOCUMENT IS THE PROPERTY OF THE AVERY DENNISON CO. AND IS TO BE RETURNED TO THE COMPANY ON DEMAND.

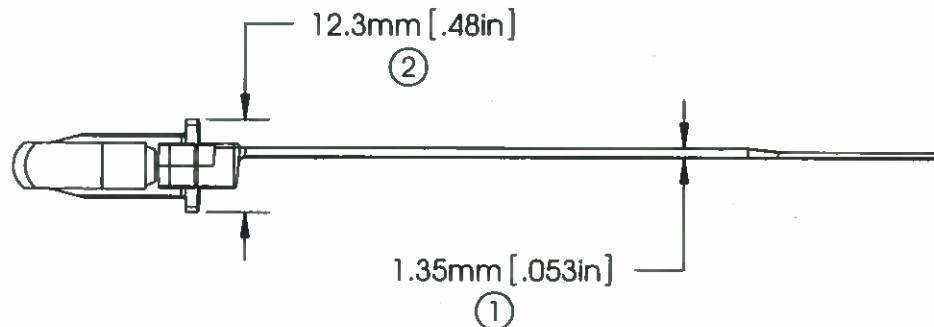
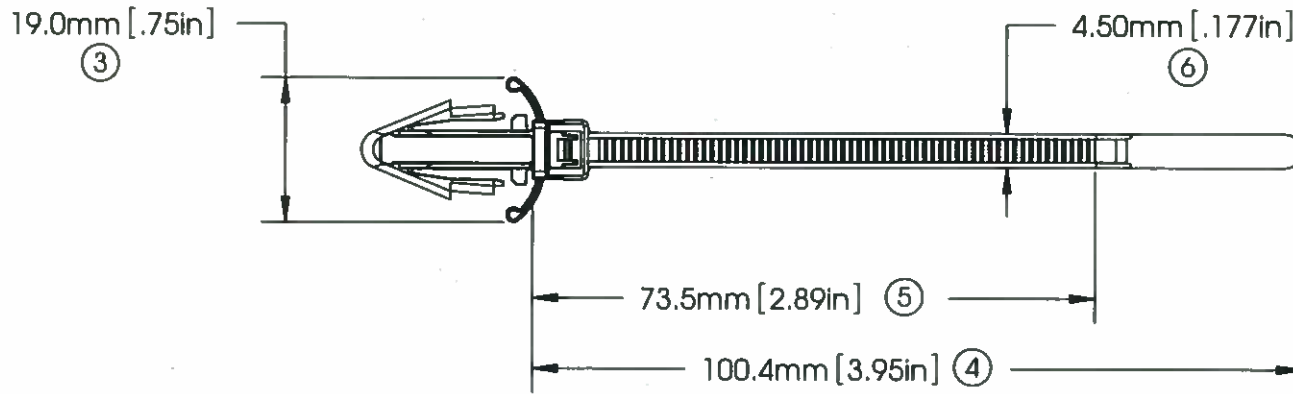

MOUNTING:	Ø9.25mm TO Ø10.00mm HOLE IN 2.0mm TO 10.0mm THICK PANEL
TENSILE STRENGTH:	25 LBF / 111.2N MIN.
OPERATING TEMP RANGE:	-40°F (-40°C) TO 220°F (105°C)
WEIGHT:	1.7 GRAMS EACH
BUNDLE DIAMETER:	Ø 1/4" (Ø 6.4mm) TO Ø 3/4" (Ø 19.1mm)
INSTALLATION TOOL:	12001 - HAND TOOL 12500 - PNEUMATIC TOOL
TOOL TENSION SETTING:	6 - 8
PACKAGING:	500/BAG, 5,000/CASE

APPROVALS:	ENG. APPR.	<i>[Signature]</i> 7/30/15
	Q.A. APPR.	<i>[Signature]</i> 7/30/15
SPECIFIED TOLERANCES		MATERIAL
INCHES	(mm)	NYLON 6/6
.XX ± .03	.X ± .7	HEAT STABILIZED, IMPACT MODIFIED
.XXX ± .010	.XX ± .25	COLOR
ANGULAR: ± 2°		BLACK

	<b>AVERY DENNISON</b>		<small>FASTENER DIVISION FITCHBURG, MA 01420 U.S.A. TEL: 1-800-225-5913 FAX: 978-353-8157</small>	
	<b>DESCRIPTION</b> 9.5mm ARROW PUSH MOUNT 4" LENGTH			
STOCK NO.		20060-0		REV. D